



A Safe Fleet Brand

Roll Rite, LLC and its entire staff would like to not only Thank You but congratulate you on your purchase of what we feel to be the finest line of tarping systems in the industry. In this booklet you will find:

DC Series Installation Manual

(# 101630)

Questions? Contact Customer Service @ 800-297-9905

Or

Parts Diagrams see "Parts and Diagrams" section on web at www.rollrite.com

In this booklet you will find:

TOWER INSTALLATION	3
<i>U-Bolt Style mount</i>	4
<i>Side Frame Style mount</i>	4
PIVOT INSTALLATION.....	5
<i>External Pivot Installation: (pivot found in kit # 69200 & 69203)</i>	5
Mount Installation.....	5
Adjustable Leg Installation.....	7
Installing the Pivot Pin Mounting Bracket.....	7
Install the Pivot Set.....	8
<i>Stationary Pivot Installation (Top Mount): (Pivot found in kit # 69400)</i>	9
Mounting Bracket Location.....	9
Stationary Mounting Kit Installation	10
Pivot Box Location	11
Pivot Box Installation	12
<i>Narrow Profile Sliding Pivot Installation: (Pivot found in Sys. # 69350)</i>	13
Narrow Profile Sliding Pivot Mounting Bracket Installation.....	13
Positioning the pivot set on the mounts	14
<i>Lay Down Sliding Pivot Installation: (Pivot found in Sys. # 69300)</i>	16
Pivot Point Location.....	16
Vertical Mount Sliding Pivot Mounting Bracket Installation.....	17
Horizontal Mount Sliding Pivot Mounting Kit Installation	19
Horizontal Pivot Installation and Mounting Kit Adjustments.....	20
WIRING.....	22
ROLL-RITE “BLACK BOX” OPERATIONAL INSTRUCTIONS	23
<i>Black Box Operation</i>	23
<i>Lock Out Feature</i>	24
SYNCHRONIZING VALVE INSTALLATION.....	25
<i>Mounting the Synchronizing Valve</i>	25
<i>Plumbing the Synchronizing Valve for Bleeding</i>	26
<i>Bleeding the Sliding Pivots</i>	26
<i>Plumbing the System for Operation</i>	27
TARP INSTALLATION.....	28
ARM TIE DOWN INSTALLATION	28
TARP BOW INSTALLATION.....	29
45° PIVOT TUBE OFFSET INSTALLATION:.....	30
<i>DC 400 & DC 300 Series Tarping Systems</i>	30
<i>DC 350 Series Tarping Systems</i>	32

Questions? Contact Customer Service @ 800-297-9905

Or

Parts Diagrams see "Parts and Diagrams" section on web at www.rollrite.com

Tower Installation

Roll Rite, LLC understands the value of your time as an equipment installer. Therefore for your convenience Roll Rite pre-assembles our standard electrically operated towers. Your tower is pre-plumbed, it is pre-wired to the control box, and has been fully operated. The control box and remote key-fobs are pre-programmed and ready to use.

Note: For the tower to be correctly installed, you will need at least 12 inches of un-obstructed clearance between the back of the truck cab and the front of your longest container, guard, hoist, etc (9" of clear frame). **Tower does not have mounting brackets attached to it you will need to purchase one of the options below or build your own mounts.**

Roll Rite Offers 2 different mounting options for the tower:

- U-bolt mount which clamps the tower down to the frame (see figure 1)
- Side frame mount which allows you to bolt angle iron through the side of the frame and then attach to the tower to the angle iron. (see figure 2)

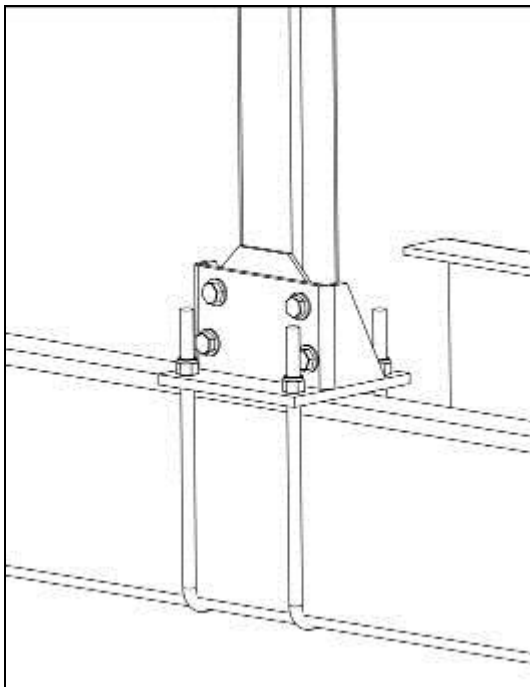

Figure 1

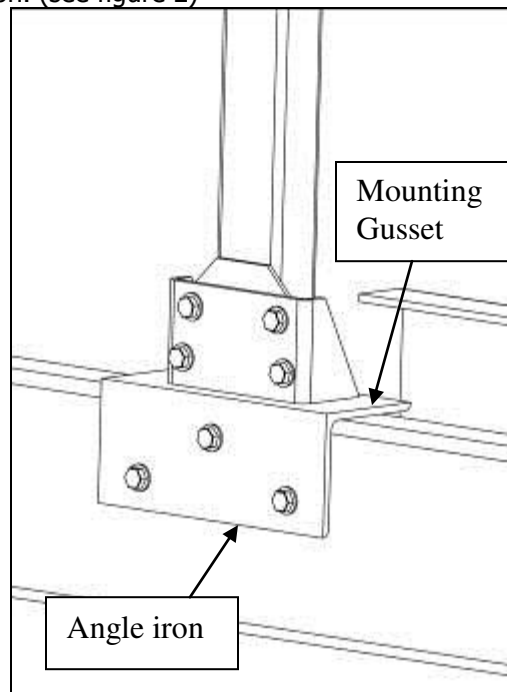
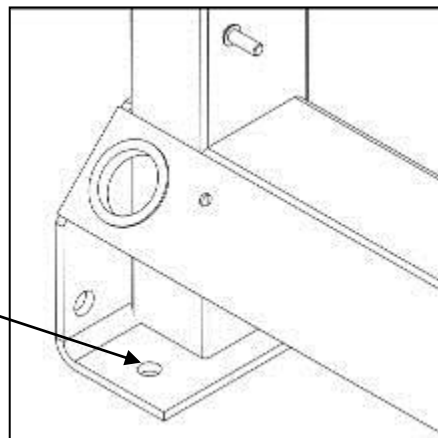

Figure 2

The holes in the bottom of the tower foot are intended for shipping purposes only. These are not sufficient for mounting the tower to the truck!



Questions? Contact Customer Service @ 800-297-9905
Or

Parts Diagrams see "Parts and Diagrams" section on web at www.rollrite.com

U-Bolt Style mount

- 1) Bolt the Mounting brackets to the tower using the provided bolts
- 2) Locate the 5/8" x 14" U-Bolts. (Part# 18714)
- 3) Place the tower on the frame rails as shown above in figure 1.
- 4) Check to make sure that the tower will not interfere with any other components of the truck or hoist.
- 5) Square the tower with the cab of the truck.
- 6) Slide the U-bolts around the frame rails and thru the holes in the tower feet.

Note: The "U" bolts supplied are meant to accommodate varying frame rail widths. Spread the threaded end of the "U" bolt if necessary.

- 7) Fasten the tower in place by tightening the 5/8" No. 11 high nuts (part# 18636) on the u-bolts.

Side Frame Style mount

- 1) Locate the 2 - 6" x 6" angle iron pieces (see figure 2)
- 2) Place them on the frame rails of the truck across from each other
Note: One or both of the angle iron pieces may need to be trimmed to fit on the frame
- 3) Place the tower on the angle iron pieces
- 4) Center the tower on the frame of the truck and square it with the cab
- 5) Clamp the tower to the angle iron pieces
- 6) Bolt the angle iron pieces to the frame rails
- 7) Using 2 bolts on each side bolt the mounting gussets to the tower (see figure 2)
- 8) Tack the mounting gussets to the angle iron
- 9) Remove the tower and weld the mounting gussets to the angle iron
- 10) After painting install the tower to the mounting gussets using all 4 bolts on each side

Questions? Contact Customer Service @ 800-297-9905

Or

Parts Diagrams see "Parts and Diagrams" section on web at www.rollrite.com

Pivot Installation

External Pivot Installation: (pivot found in kit # 69200 & 69203)

****Refer to the diagram on page 5 to familiarize yourself with how the parts fit together.**

Mount Installation

Mounting Bracket Location

In order to correctly complete the next steps, we recommend that you load your largest container to be hauled.

NOTE: If your tower is adjustable it should be in the lowest position. If you have a stationary tower, be sure it is in the position you want it in and then proceed.

- 1) Take a measurement from where the tarp will enter the housing to a point that is slightly before the middle of the container and make a mark 3 inches below the top of the tires. REMEMBER THAT MEASUREMENT.
- 2) Measure from the back of the container using the same measurement as the first and make another mark 3 inches below the top of the tires.
- 3) Measure from the first mark to the second mark, divide that measurement in half and make a mark. This is where the mount needs to be centered. (Refer to **Fig. 1**)

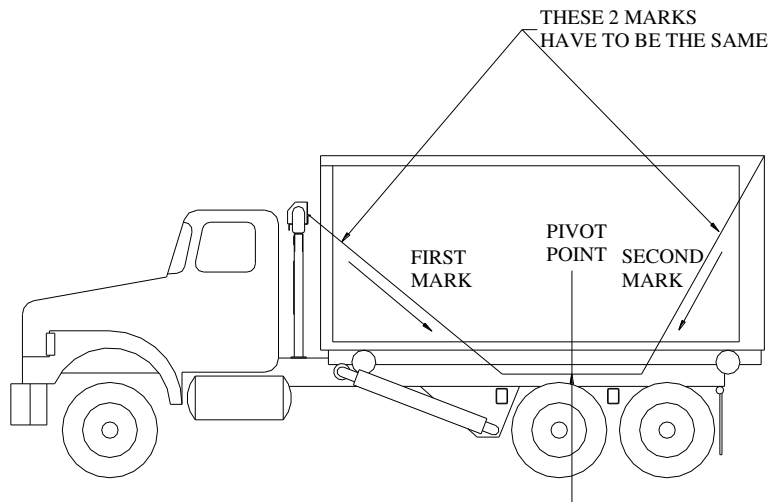

Figure 1

- 4) Double-check the center point by measuring from where the tarp enters the housing to the center point and from the back of the container to the center point. These 2 measurements have to be the same.

Questions? Contact Customer Service @ 800-297-9905

Or

Parts Diagrams see "Parts and Diagrams" section on web at www.rollrite.com

- 5) Repeat Steps 1 – 4 on the opposite side of the truck.
- 6) To double-check that these legs will not interfere with the tilt cylinders, you will need to raise the tilt bed to the maximum tilt. The legs need to be behind the cylinders at this point. (Refer to **Fig. 2**)

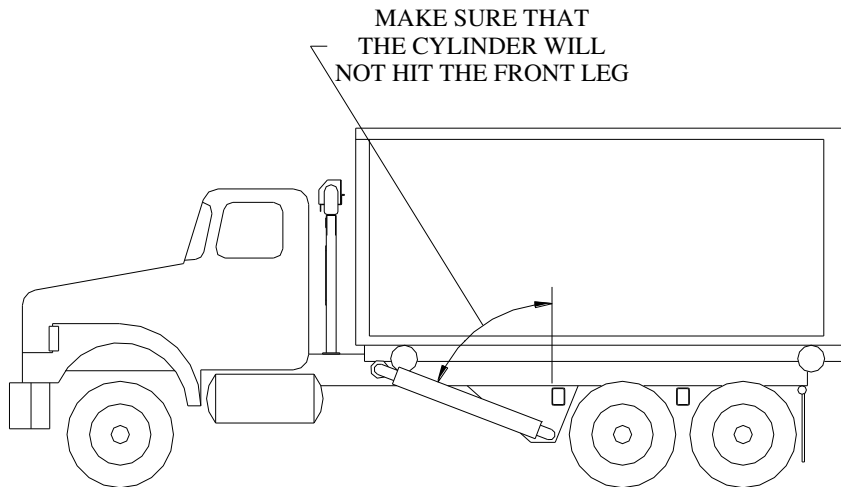

Figure 2

- 7) If there is not a pad bolted to the frame in this location, center a mounting pad on the mark established for the center point and bolt it to the truck. This is where the pivot point of the system will be.
- 8) Center the stationary leg on the pad and tack weld it in place.
- 9) Make sure that it is level and square with the truck and finish welding the leg to the pad. Refer to the figure 3 below.

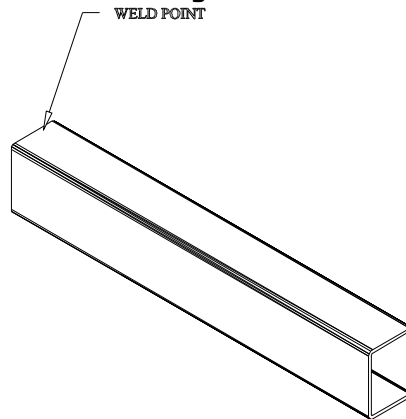

Figure 3

- 10) Repeat the above steps for the opposite side.

Adjustable Leg Installation

- 1) Insert the adjustable leg into the stationary leg.
- 2) Determine how far the pivot pin is to stick out from the truck by sliding the adjustable leg in or out. Refer to figure 4 below.

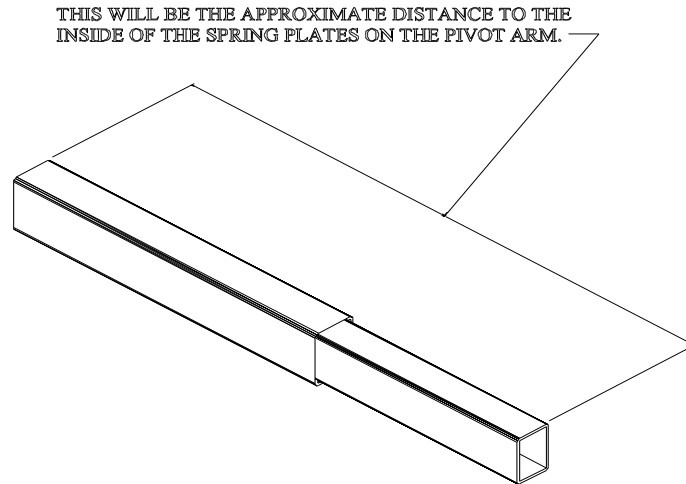

Figure 4

- 3) Tack weld the leg in place.
- 4) Make sure that the leg is adjusted correctly and finish welding the leg.
- 5) Repeat the above steps for the opposite side.

Installing the Pivot Pin Mounting Bracket

- 1) Center the pivot pin mounting bracket on the adjustable leg. Refer to figure 5.

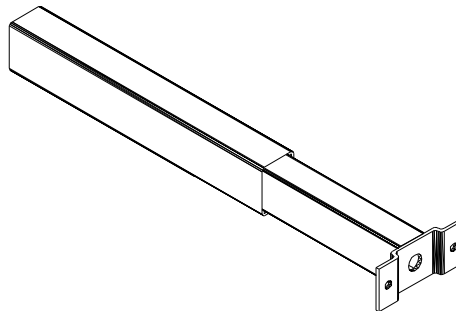

Figure 5

Questions? Contact Customer Service @ 800-297-9905
Or
Parts Diagrams see "Parts and Diagrams" section on web at www.rollrite.com

- 2) Tack weld the bracket in place.
- 3) Make sure that the bracket is square with leg and the truck and finish the weld.
- 4) Repeat the above steps for the opposite side.

Install the Pivot Set

- 1) Refer to Fig. 6 below to identify driver and passenger arms.

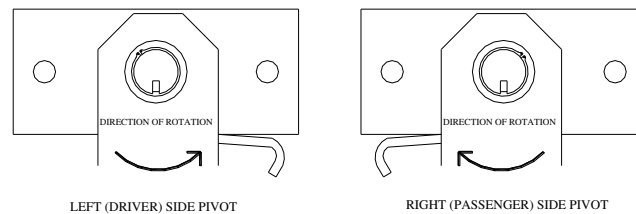

Figure 6

- 2) Bolt the driver side pivot arm to the driver side pivot mount. Repeat with the passenger side arm.
- 3) Install the clevis pin in the center hold under the spring hooks.
- 4) Now that the pivots are installed proceed to the tarp and tarp bow installation sections.

Stationary Pivot Installation (Top Mount): (Pivot found in kit # 69400)

Mounting Bracket Location

In order to correctly complete the next steps, we recommend that you load your largest container to be hauled.

NOTE: If your tower is adjustable it should be in the lowest position. If you have a stationary tower, be sure it is in the position you want it in and then proceed.

- 1) Take a measurement from where the tarp will enter the housing to a point that is slightly before the middle of the container and make a mark 3 inches below the top of the tires. REMEMBER THAT MEASUREMENT.
- 2) Measure from the back of the container using the same measurement and make another mark 3 inches below the top of the tires.
- 3) Measure from the first mark to the second mark, divide that measurement in half and make a mark. This is where the mount needs to be centered. (Refer to **Fig. 1**)

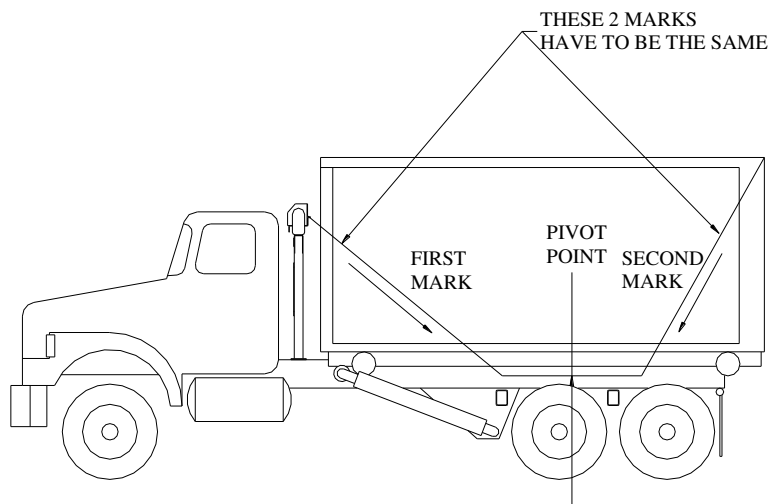

Fig. 1

- 4) Double-check the center point by measuring from where the tarp enters the housing to the center point and from the back of the container to the center point. These 2 measurements have to be the same.
- 5) Repeat Steps 1 – 4 on the opposite side of the truck.

Questions? Contact Customer Service @ 800-297-9905
Or

Parts Diagrams see "Parts and Diagrams" section on web at www.rollrite.com

Stationary Mounting Kit Installation

The mounting kit consists of 2 pieces of 3" X 4" square tubing, 2 adjusting legs, and 1 top plate for each side. (Refer to **Fig. 2**)

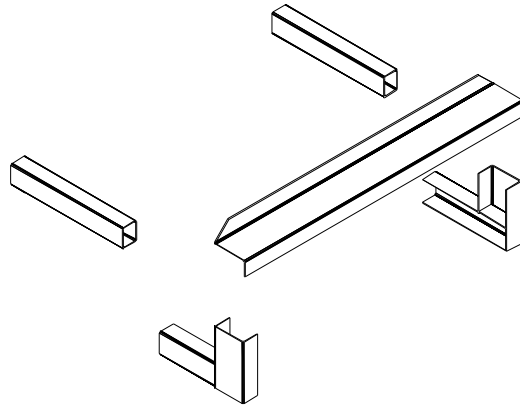

Fig. 2

- 1) Mount the steel tubing to the truck, 3 inches below the top of the tires. Make sure that the tubing is not spaced more than 5 ft. apart and that neither piece of tubing is more than 4-1/2 ft away from the center point that was established earlier.
- 2) Slide the "L" shaped adjusting legs over the tubing, as shown in Fig. 3, and weld in place.

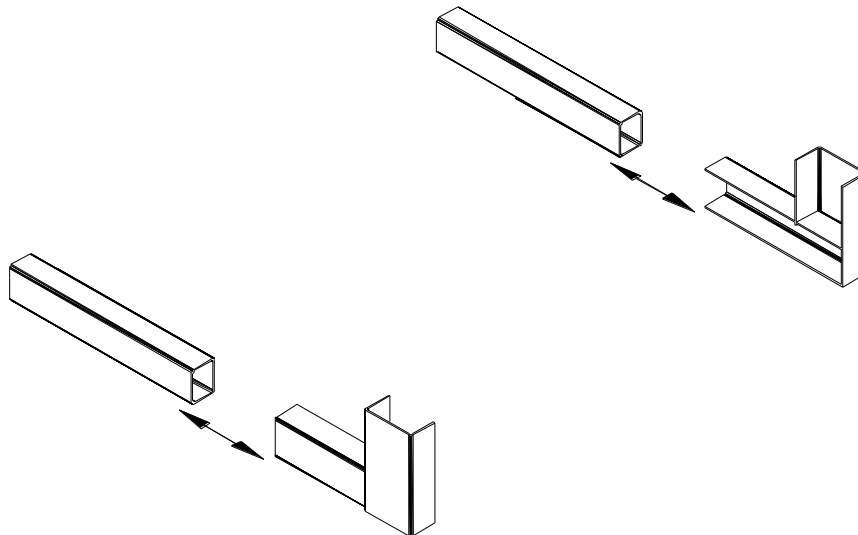

Figure 3

- 3) Place the top plate on the "L" shaped pieces and center the plate as necessary. Make sure that neither end of the plate is further than 4-1/2 ft. from the center point and weld in place.

Questions? Contact Customer Service @ 800-297-9905
Or

Parts Diagrams see "Parts and Diagrams" section on web at www.rollrite.com

- 4) To double-check that the front legs will not interfere with the tilt cylinders, you will need to raise the tilt bed to the maximum tilt. The front legs need to be behind the cylinders at this point. (Refer to **Fig. 4**)

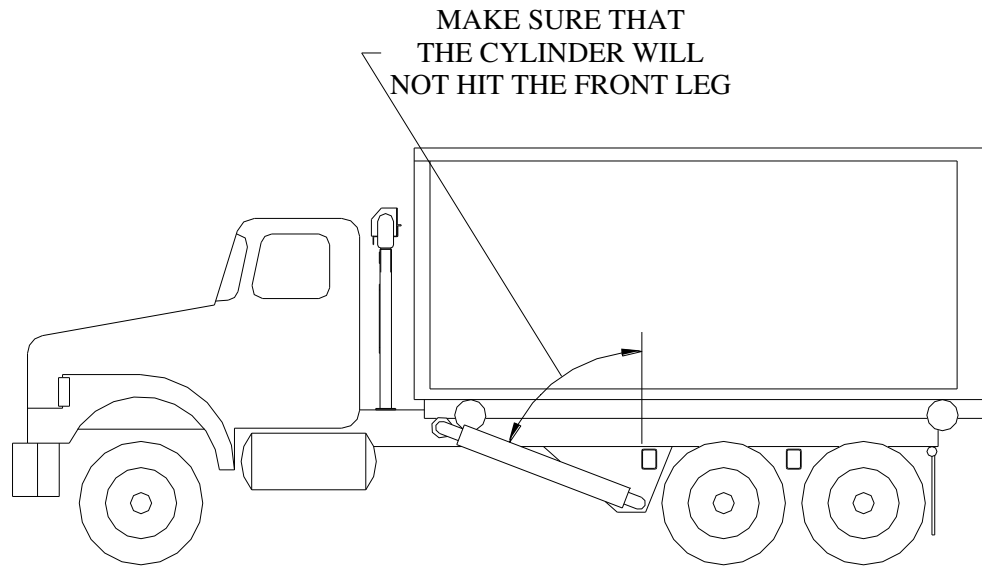

Figure 4

Pivot Box Location

- 1) Take a measurement from where the tarp will enter the housing to a point that is slightly before the middle of the container and make a mark on the mounting bracket. REMEMBER THAT MEASUREMENT.
- 2) Measure from the back of the container using the same measurement as the first and make another mark on the mounting bracket.
- 3) Measure from the first mark to the second mark, divide that measurement in half and make a mark. This is where the pivot pin in the box needs to be centered. (Refer to **Fig. 5**)

*Questions? Contact Customer Service @ 800-297-9905
Or*

Parts Diagrams see "Parts and Diagrams" section on web at www.rollrite.com

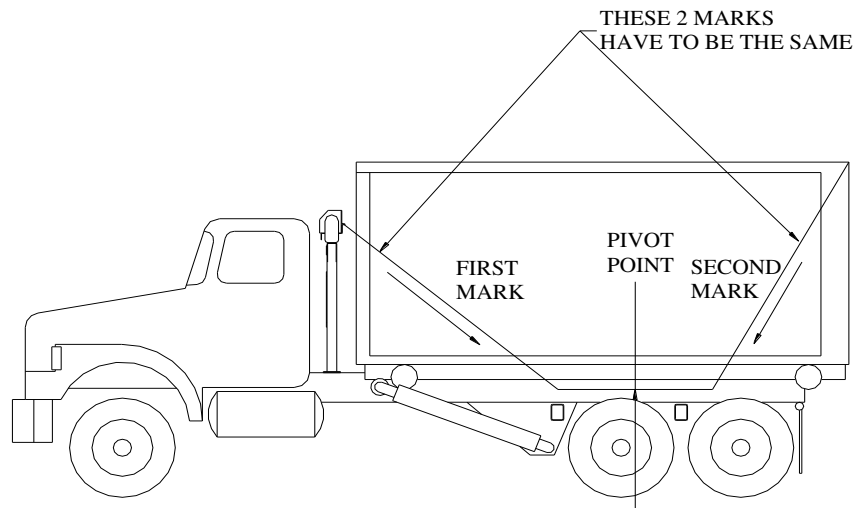

Figure 5

- 4) Double-check the center point by measuring from where the tarp enters the housing to the center point and from the back of the container to the center point. These 2 measurements have to be the same.
- 5) Repeat Steps 1 – 4 on the opposite side of the truck.

Pivot Box Installation

- 1) Center the driver side pivot pin with the mark made in the previous steps. The pivot boxes need to be flush with the outside edge of the bracket.
- 2) Measure from the outside front and back edge of the pivot box to the frame. Make sure that these measurements are the same. This will let you know if the boxes are square with the truck or not.
- 3) Mark and drill the holes to mount the pivot box to the mounting bracket.
- 4) Repeat the above steps for the opposite side.
- 5) Now that the pivots are installed proceed to the tarp and tarp bow installation sections.

Narrow Profile Sliding Pivot Installation: (Pivot found in Sys. # 69350)

This style pivot Mounts on a 2.5" x 2.5" mounting tube. This tube is intended to be mounted on top of a Roll Rite mounting bracket set or can be mounted on custom built fender mounts, extension off of fender mounts or if retrofitting an older system can be mounted on current mounts.

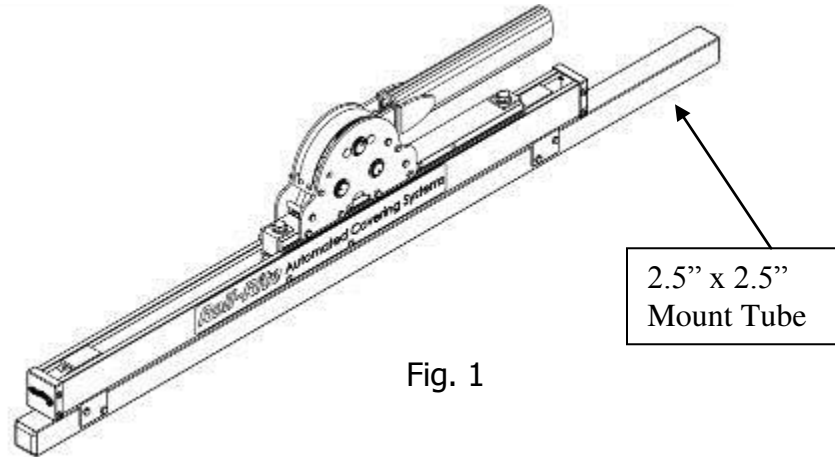

Fig. 1

Narrow Profile Sliding Pivot Mounting Bracket Installation

- 1) This kit includes 4 chassis mounting assemblies. These will need to be cut to length and height.
 - a. Positioning the chassis mounts.
 - i. Pivot set will typically straddle the lead drive axle and mount off the same mounting plates that a fender mount would be mounted to.
 - ii. Try to mount as close to the center point of the frame vertically to allow room for any gusseting that you may need to add. If the axle mounts are in the way mount above them. Also when mounting between axle try to center up to allow maximum clearance.

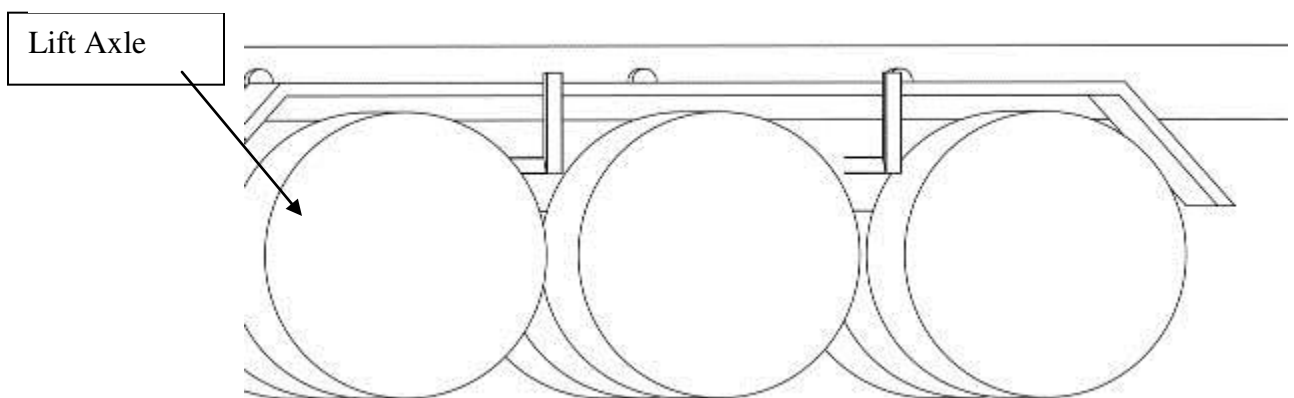

Fig. 2

Questions? Contact Customer Service @ 800-297-9905
Or
Parts Diagrams see "Parts and Diagrams" section on web at www.rollrite.com

- b. Figure the length of the chassis mounting tubes
 - i. Measure frame width including mounting plates (which may or may not already be on truck and is typically where the fender mounts attach.) Mounting plates are typically 1/2" thick plates bolted to the chassis.
 - ii. Subtract distance measured in above step from 107 1/2" (108" is max legal D.O.T. width)
 - iii. Divide # found in above step by 2 and cut chassis mounting tubes to length
 - c. Tack the mounting bracket angles to the mounting pads. Double check that they are not more then 107 1/2" overall width and that they are plumb and square.
 - d. To figure length of elevation tubes
 - i. Measure from the chassis mount tube up to the bottom edge of the fender above the tire.
 - ii. Measure that same distance up from the chassis mount tube and mark the elevation tubes (to allow for ease of tire changes the pivot mount tube should not be lower then the bottom of the fender above the tire.)
 - iii. Cut the elevation tubes along the mark made in previous step. It may be easier to remove the mounts from the truck to do this.
 - e. Weld the mounts up and add gussets as needed. If you removed the mounts from the truck in the previous step tack the mounts back onto the truck in the same position as before and re-check that they are plum and square before welding.
- 2) Repeat on the other side of the truck.

Positioning the pivot set on the mounts

- 1) Find the pivot point. (The steps below are assuming a standard 40 yd can @ 22' long. If Cans are not 22' long see alternate method under "Lay down Sliding Pivot")
 - a. Measure from the back edge of the tower foot to where the front of the container will be ("X" dimension in figure 3.) Divide this # in half to get Distance "Y" in figure 3.
 - b. Add "Y" as calculated in step – "a" to 138" to get dimension "Z" in figure 3.
 - c. Measure from the back of the tower foot back along the hoist frame "Z" distance as determined in step – "b". Mark this location as the pivot point.

Questions? Contact Customer Service @ 800-297-9905

Or

Parts Diagrams see "Parts and Diagrams" section on web at www.rollrite.com

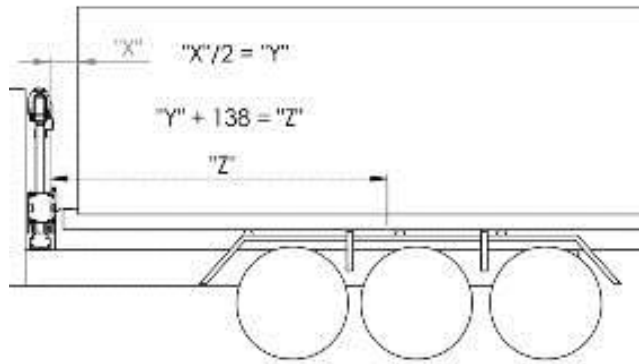

Fig. 3

- 2) Position the 80" long 2 1/2" x 2 1/2" square tubes that came in the pivot set on top of the elevation tubes. To ensure that the pivot assembly mounts will land on the horizontal mounting tube - make sure that there is at least 25" of tube behind the pivot point and at least 33" in front of the pivot point and weld this horizontal tube in place on top of the elevation tubes.
- 3) Set the pivot assembly on the horizontal mounting tube (installed in previous step) so that the sliding assembly is to the rear and the center pivot pin is in line with the pivot point (see fig. 4)

Note: To ensure proper operation the cylinder needs to be slid all the way to the back (as shipped and as shown below in Fig. 4) at the time of install.

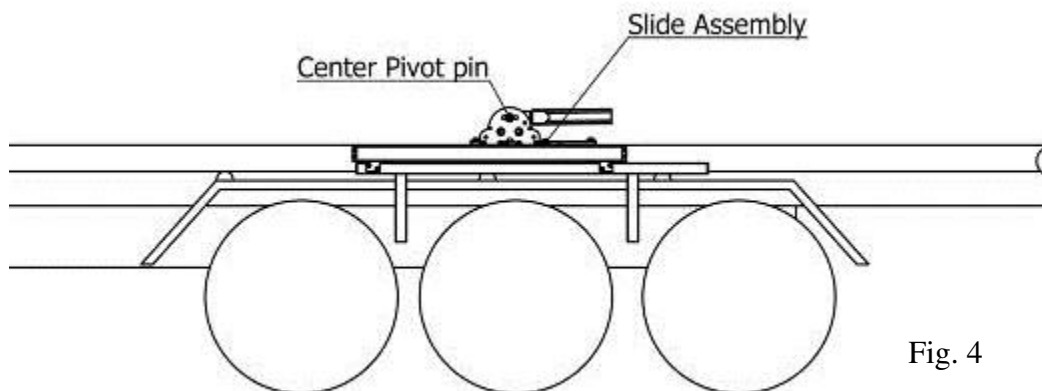

Fig. 4

- 4) Once in position, drill 4 - 3/8" clearance mounting holes through the 2 1/2" horizontal tube using the holes in the aluminum mounts in the pivot assembly as guides. Set the pivot assembly aside and paint mounting brackets. Once brackets are painted bolt in pivot assembly back in place.
- 5) Repeat on the other side of the truck.
- 6) Proceed to section on installation of the "Synchronizing Valve" in the next section.

Questions? Contact Customer Service @ 800-297-9905

Or

Parts Diagrams see "Parts and Diagrams" section on web at www.rollrite.com

Lay Down Sliding Pivot Installation: (Pivot found in Sys. # 69300)

Pivot Point Location

***In order to correctly complete the next steps, we recommend that you load your largest container to be hauled. While you are loading your largest container, raise your tilt bed to its highest point and mark the frame at the back edge of the cylinders. You will need this mark for later steps, but it is easiest to do it now.**

- 1) With the tower in the lowest position, take a measurement from where the tarp will enter the housing to a point that is slightly before the middle of the container and make a mark. REMEMBER THAT MEASUREMENT. Refer to Fig. 1 below.

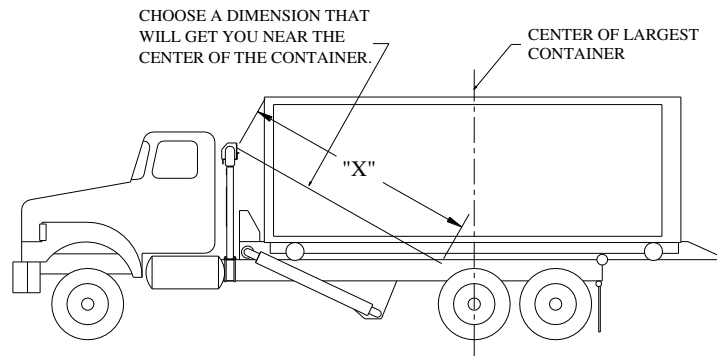

Figure 1

Note: The pivot point needs to be about 2 inches below the top of the rails on the tilt bed and no less than 4 inches above the tires.

- 2) Measure from the back of the container to the frame using the same measurement as the first. Make a mark. Refer to Fig. 2 below.

THESE MEASUREMENTS NEED TO BE THE SAME AND END AT ABOUT THE SAME HEIGHT ON THE FRAME OR TILT RAIL.

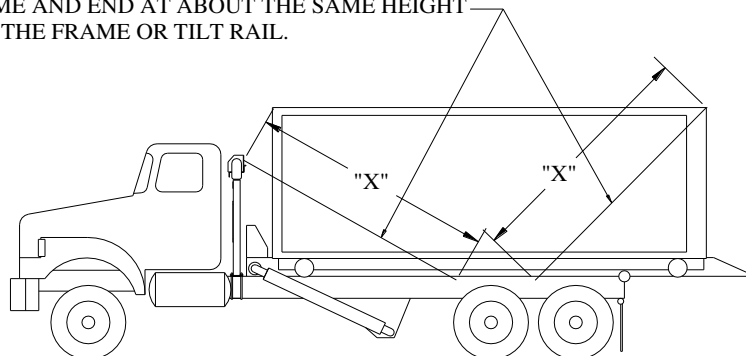

Figure 2

- 3) Measure from the first mark to the second mark, divide that measurement in half and make a mark. This is where the pivot point of the system will be. (Refer to Fig. 3)

Questions? Contact Customer Service @ 800-297-9905

Or

Parts Diagrams see "Parts and Diagrams" section on web at www.rollrite.com

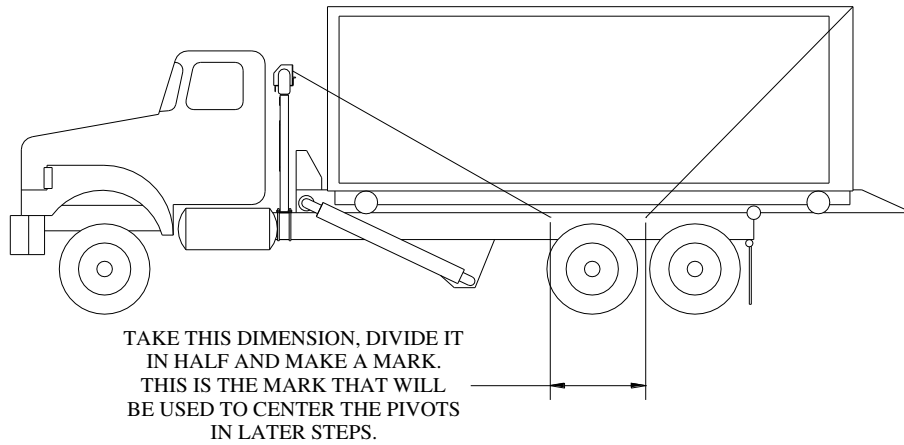

Figure 3

- 4) Double-check the center point by measuring from where the tarp enters the housing to the center point and from the back of the container to the center point. These 2 measurements have to be the same.

Vertical Mount Sliding Pivot Mounting Bracket Installation

- 1) This style pivot is designed to mount off or in the same location as the fender mounts for the front axle on a tandem truck or the center axle on a tri-axle truck. (For single axle truck see "Pivot Point Location" section on previous page.)
- 2) The mounting kit is designed to have the rear mounting leg to be placed centered between the drive axles. To insure clear clearance the top of the tube should not be more than $8 \frac{13}{16}$ " down from the top of the tire or fender, as part of the pivot box will sit above the tire or fender. (Refer to Fig. 4)

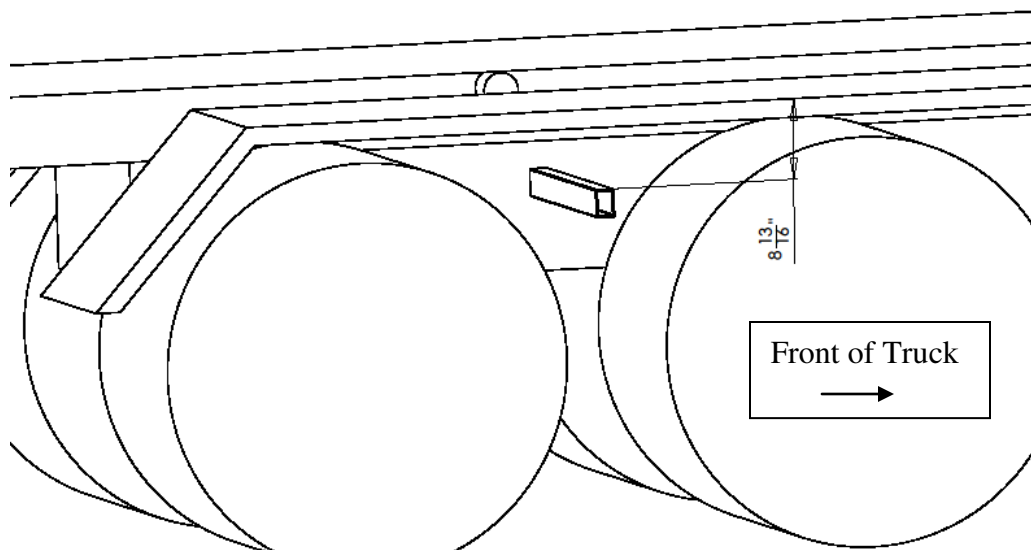

Figure 4

- 3) Front and rear mounting leg must be spaced evenly around front drive axle. (See Fig. 5 measurement may vary)

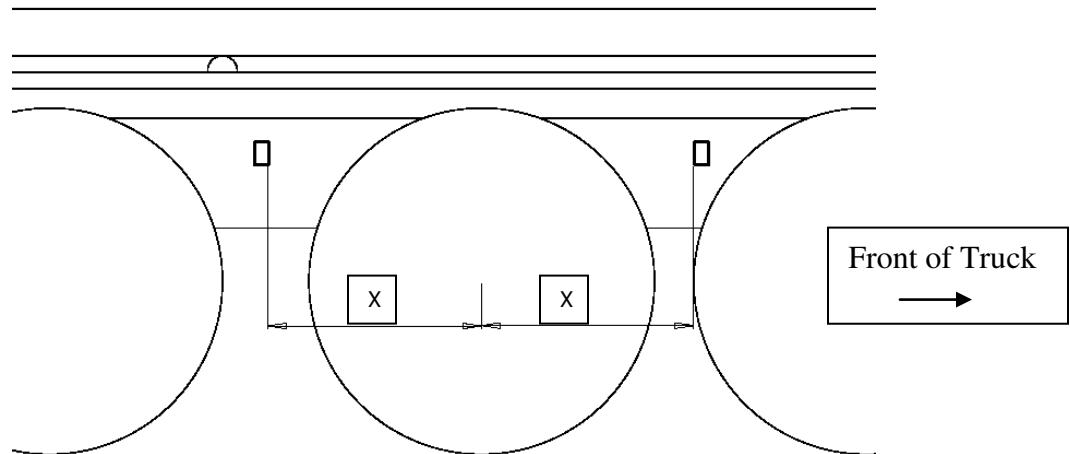

Figure 5

- 4) Repeat steps one through 3 on the other side of the truck.
5) Measure from the end of the mounting tube on one side to the end of the mounting tube on the other side. This dimension needs to be $93 \frac{3}{4}$ " , cut tubes off equally if needed to achieve this dimension.
6) Position the flat mounting pads on the end of the tubes so that the mounting holes are 53 " on center and no more than $6 \frac{3}{4}$ " Down from the top of the fender or tire. You may need to notch your mounting tubes to clear the mounting bolt. Weld pads in place. (See Fig. 6)

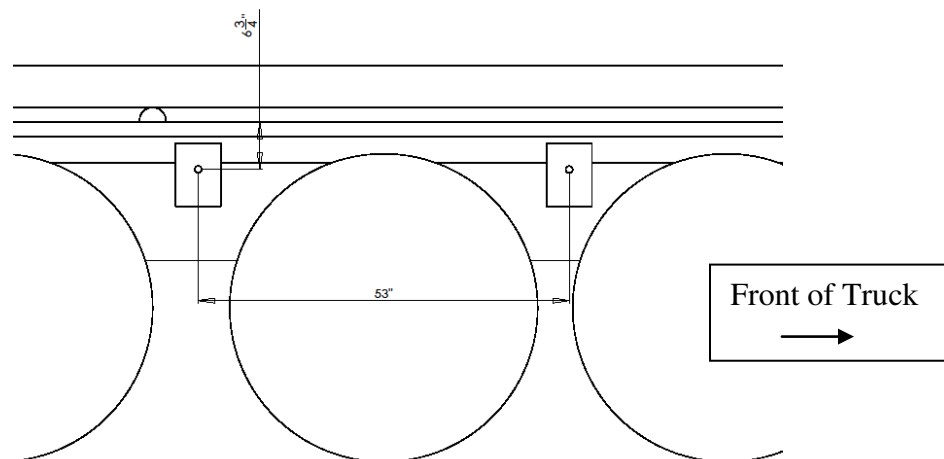

Figure 6

Horizontal Mount Sliding Pivot Mounting Kit Installation

Note: The aluminum sliding pivots have part of the mounting kit attached to them already. (4 steel pads that are bolted to the cast end caps.) The rest of the mounting kit consists of (4) width-adjusting, "L" shaped legs, (4) single pieces of 3" x 4" square tubing, (2) 2 3/16" x 3 1/4" steel caps, (2) 3 1/8" x 5" steel caps, (2) 7 x 10 steel plates, and (2) 2 1/2 x 3 1/2 x 21" pieces of tubing. Refer to fig. 7 below.

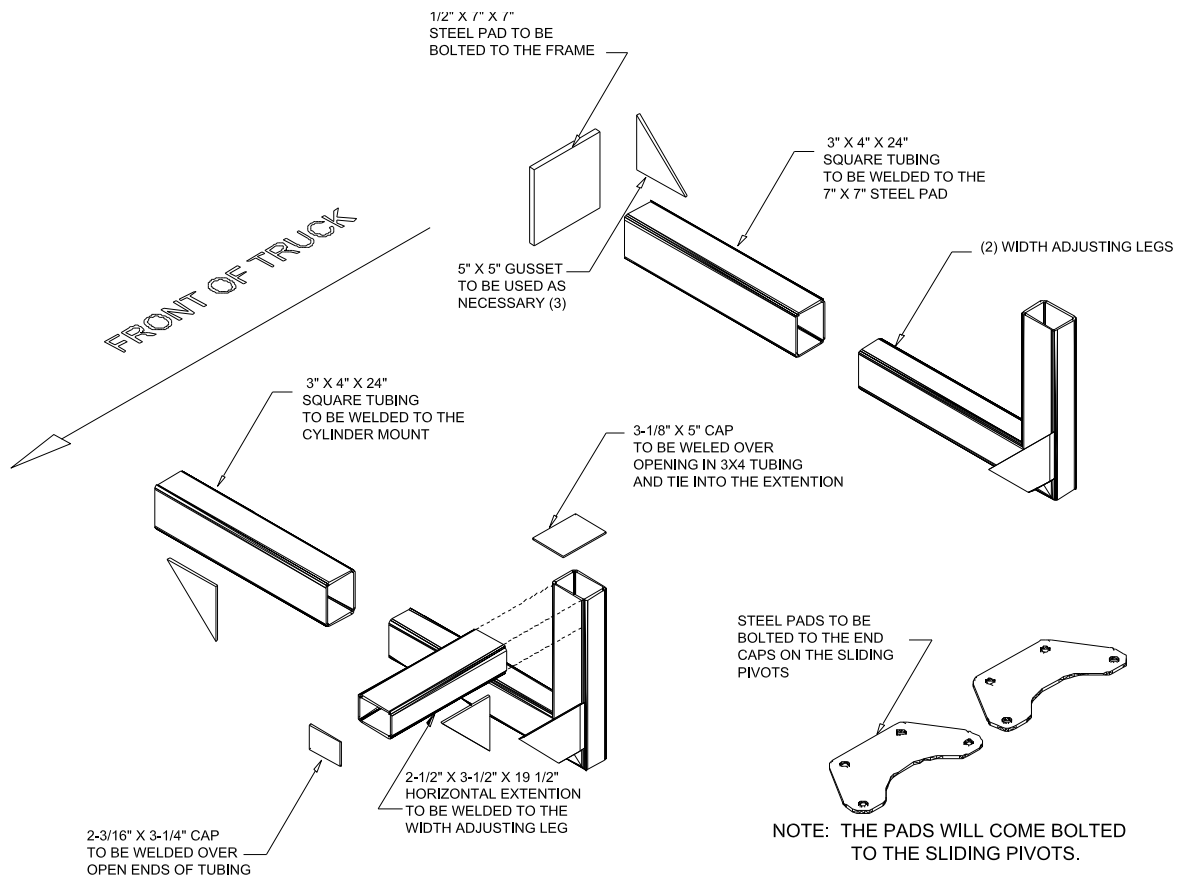

Figure 7

Note: The front legs of the mounting kit will need to be placed behind the mark indicating the back edge of the cylinder. The back legs will need to be mounted 16" back from the center point determined earlier. The 3" X 4" legs should set about 17 inches below the top of the boom or tilt frame.

- 1) Find a suitable position in front of the front axle for the 3" x 4" tube. Remember to stay behind the back edge of the cylinders at max tilt.
- 2) Weld 1 of the 3" X 4" X 18" pieces of tubing to the cylinder mount, 17" down from the top of the tilt frame, on each side of the truck.
- 3) Measure towards the back from the center point 16" and bolt the (2) 7" X 10" pads to the truck frame on each side, centered at 17" down from the top of the tilt frame. This is done to avoid welding directly to the frame of the truck. Refer to illustration 1 below.

Questions? Contact Customer Service @ 800-297-9905

Or

Parts Diagrams see "Parts and Diagrams" section on web at www.rollrite.com

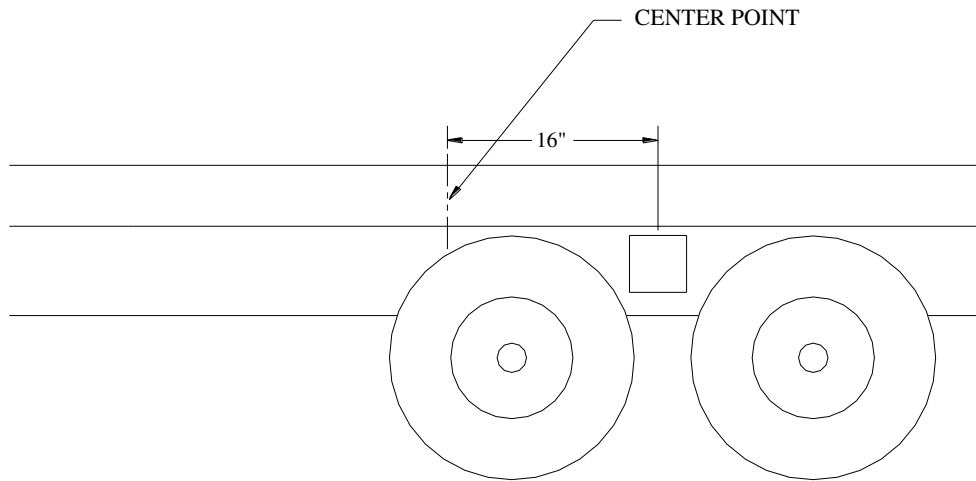

Illustration 1

- 4) Weld the square tubing to the pads that are bolted to the frame. Make sure that they are level and square with the truck frame. They also need to be approximately 17" down from the top of the tilt bed.

Horizontal Pivot Installation and Mounting Kit Adjustments

Note: The sliding pivots are marked as passenger side and driver side.

- 1) Slide the "L" shaped pieces into the tubes that are mounted to both sides of the truck. With a 108" width regulation, the legs can only be 85 1/4" from outside to outside. Refer to Fig. 8

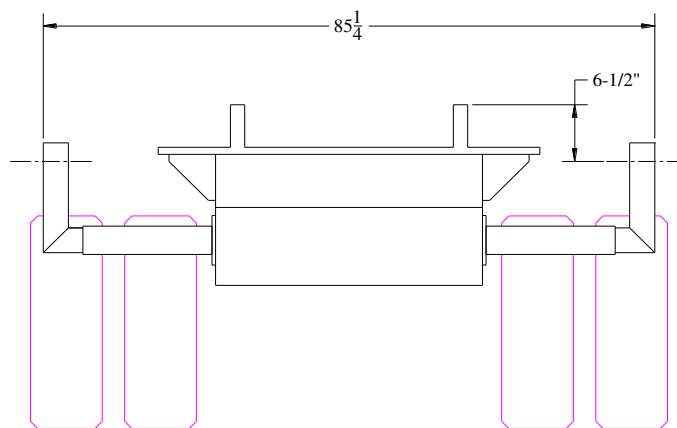

Figure 8

- 2) Measure from the top of the bed down a minimum of 6 1/2" and put a mark on all 4 up-right legs, as shown above in Fig. 5. This height may vary based on clearance issues.
- 3) Cut the up-right legs off at the marks made in the previous step.

Questions? Contact Customer Service @ 800-297-9905

Or

Parts Diagrams see "Parts and Diagrams" section on web at www.rollrite.com

4) Measure the length of the sliding pivots. Determine if you need to extend the mounts to get the center of the pivot pin in the sliding pivots to line up with the center point mark made earlier. Refer to figures 7 & 8 on following pages.

Note: There are (2) 21" pieces of 2-1/2 X 3-1/2 square tubing that can be cut and used as extensions included in this kit. An example of how the extension can be used is shown in figure 9 below.

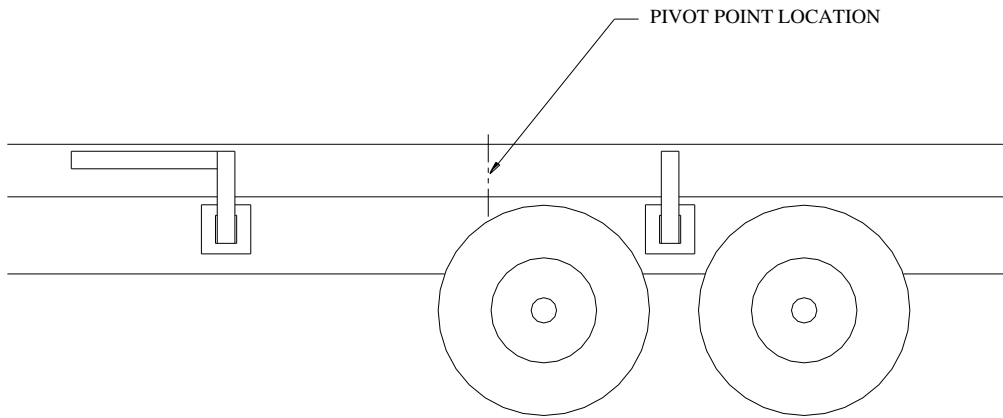

Figure 9

5) Cut the extension pieces to the desired length and weld them horizontally to the front and/or back legs of the mounts. Use the (2) pieces of 3 1/8" X 5" pieces of steel strap to tie the extension legs to the "L" shaped legs. Refer to Fig. 7 on next page and Fig. 4 on page 13 for parts descriptions.

6) Set the driver's side pivot on the up-right legs and center the pads on the tubing as shown below in figure 10.

Note: To ensure proper operation the cylinder should be slid all the way to the back (as shipped and shown in Fig.10)

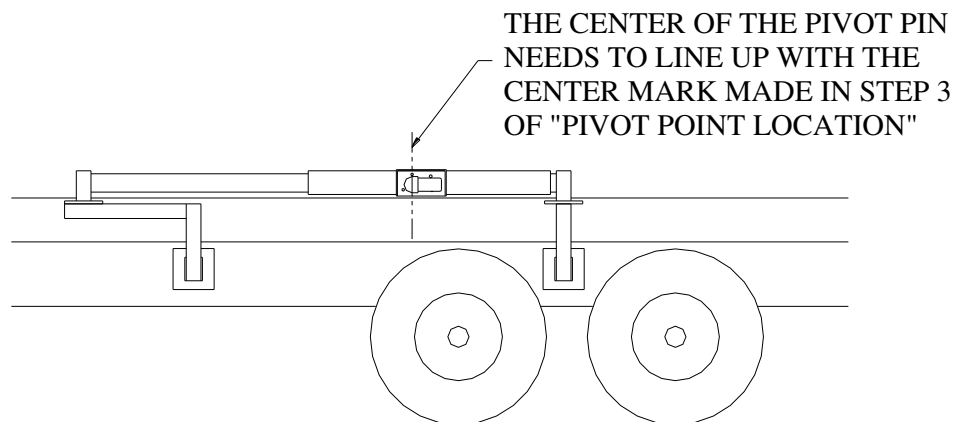

Figure 10

- 7) Measure from the frame rail, or something parallel with the frame rail, to the inside front and back edge of the pivot. Make sure the measurements are equal. This will make the pivots parallel with the truck bed and each other.
- 8) Weld the "L" shaped legs in place. Make sure that they are 85 1/4" from outside to outside.
- 9) Weld the pads that are on the pivots to the up-right legs of the mounting kit.
- 10) Repeat steps 6 thru 9 for the passenger side if not already done.

Wiring

- 1) Spooled around the black control box will be one end of the power wires. Depending on voltage and application this may be 2, 4 or 6 ga. wire. Run these wires down to the battery or approved power supply.
****If mounting system on a Roll Off trailer it is required to use 2 gauge wire for main power and ground. This requires removing the standard provided 6 gauge wire from the hydraulic power unit to the plug set and installing 2 gauge wire as well as a 2 gauge tractor/trailer plug set.****
- 2) If mounting the large manual reset breaker, use the supplied fasteners.
- 3) Cut off a small piece of the wire and splice the provided circuit breaker into the positive wire as near to the power supply as possible.
- 4) Connect end of jumper wire coming off the circuit breaker to the positive post on the power supply and the negative wire to the ground side of the power supply. Ensure that all connections are secure.
- 5) Turn the control box on to verify power supply is working.

Roll-Rite "Black Box" Operational Instructions

Figure 1 - Control Box Functions

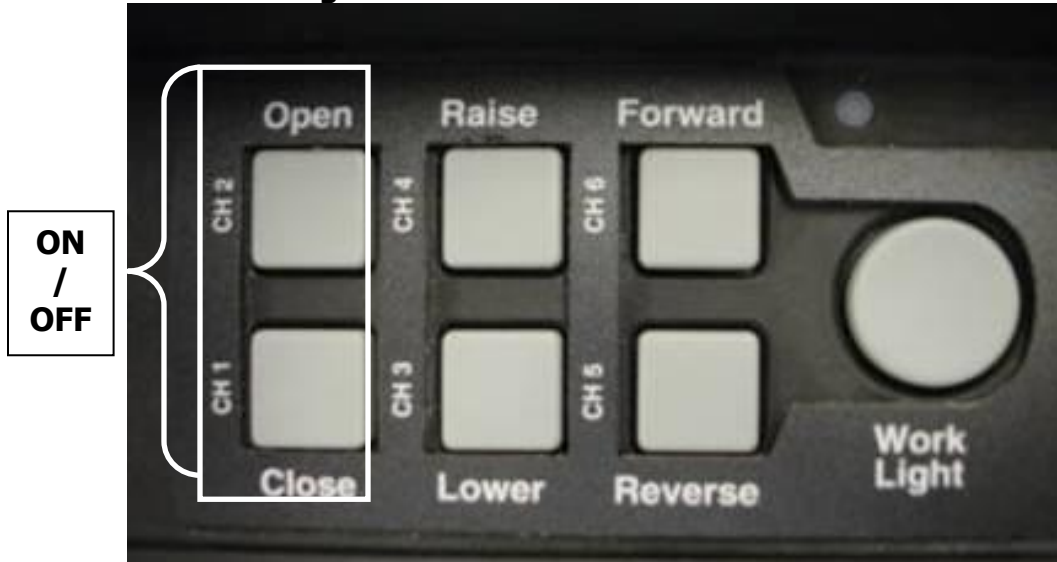
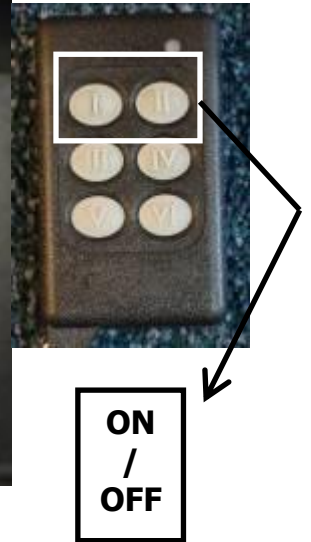

Figure 2 - Remote Functions



Black Box Operation

- ❖ **ON/OFF** – To turn the control box on or off, press CH1 and CH2 simultaneously for 2 seconds. This can be done from the box itself (see figure 1) or from the key fob (see figure 2) by pressing buttons I & II simultaneously.
- ❖ **Work Light** – If your system is equipped with work lights, turn the control box on and then press the Work Light button to turn them on or off. THIS IS NOT THE ON/OFF BUTTON FOR THE CONTROL BOX!
- ❖ **CH1 and CH2** – control buttons for output #1 on the control box (typically connected to the tarp motor). These two buttons correspond to buttons I and II respectively on the remote key fob. Pressing these two buttons at the same time and holding for 2 seconds will turn the control box on and off.
- ❖ **CH3 and CH4** – control buttons for output #2 on the control box (typically connected to hopper door or tower up/down). These two buttons correspond to buttons III and IV respectively on the remote key fob. Press and release these two buttons at the same time on the key fob to operate the work light from the remote.
- ❖ **CH5 and CH6** – control buttons for output #3 on the control box (typically connected to hopper door or sliding pivots). These two buttons correspond to buttons V and VI respectively on the remote key fob.

Programming Modes – Your black control box and remotes come preprogrammed! Do not attempt to enter the programming modes.

Questions? Contact Customer Service @ 800-297-9905
Or

Parts Diagrams see "Parts and Diagrams" section on web at www.rollrite.com

Lock Out Feature

The control box incorporates a safety feature to shut off automatically after 6 minutes of inactivity. Press buttons 1 & 2 simultaneously on the box or remote for two seconds (as described above) to power the unit back up.

To lock the box down manually (shut off), press 1 & 2 simultaneously on the box or remote for two seconds as described above.

*Boxes produced after 8-10-09 may have programmable time out feature.

To adjust the time delay before automatic shut off:

- 1) Turn the box on
- 2) Press and release the work light button 6 times, wait until the light stops flashing press the work light button again, the LED will flash once, press the work light button a final time, LED will flash once – you are now in the program mode you need to be in to adjust the automatic shut down time.
- 3) Reference diagram below, # indicated on the button represents minutes until the box automatically shuts down. "0" means it will never shut down automatically.
- 4) After selecting shut down time wait for the LED to return to green. Programming complete.



If you have an armless system your installation is complete. Test run system for proper functionality.

Questions? Contact Customer Service @ 800-297-9905

Or

Parts Diagrams see "Parts and Diagrams" section on web at www.rollrite.com

Synchronizing Valve Installation

Mounting the Synchronizing Valve

- 1) Mount the synchronizing valve near the middle of the pivots, making sure that it will not interfere with the container and that the hoses will reach each end of both sliding pivots. (Refer to Fig. 11)

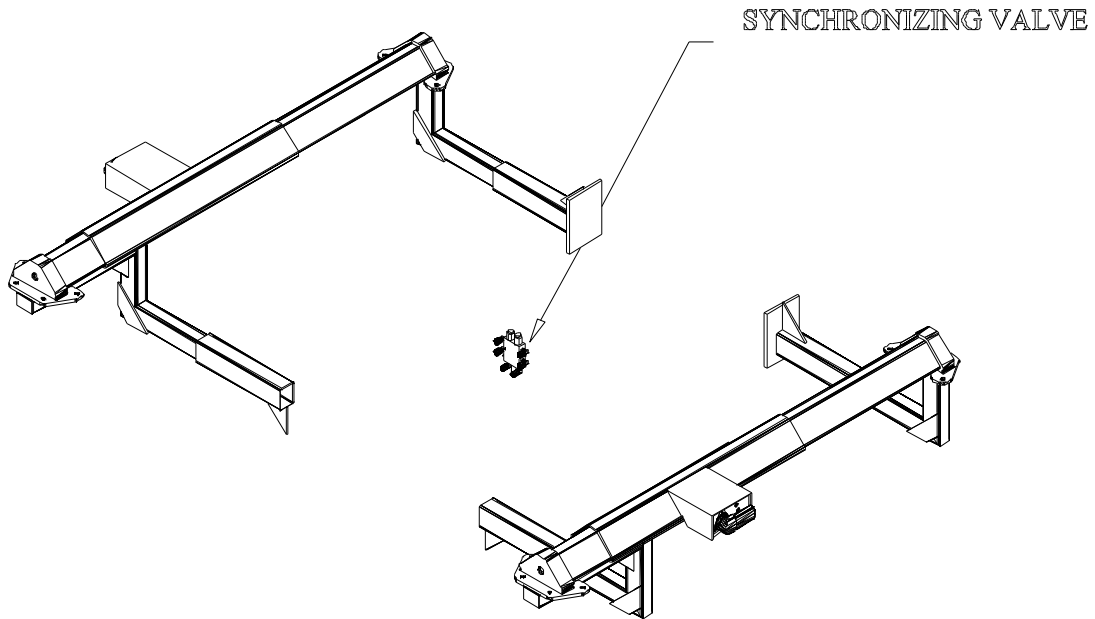

Figure 11

Plumbing the Synchronizing Valve for Bleeding

You will need to plumb the system to run the driver-side sliding pivot only. Refer to Fig. 12 to plumb the driver side for bleeding.

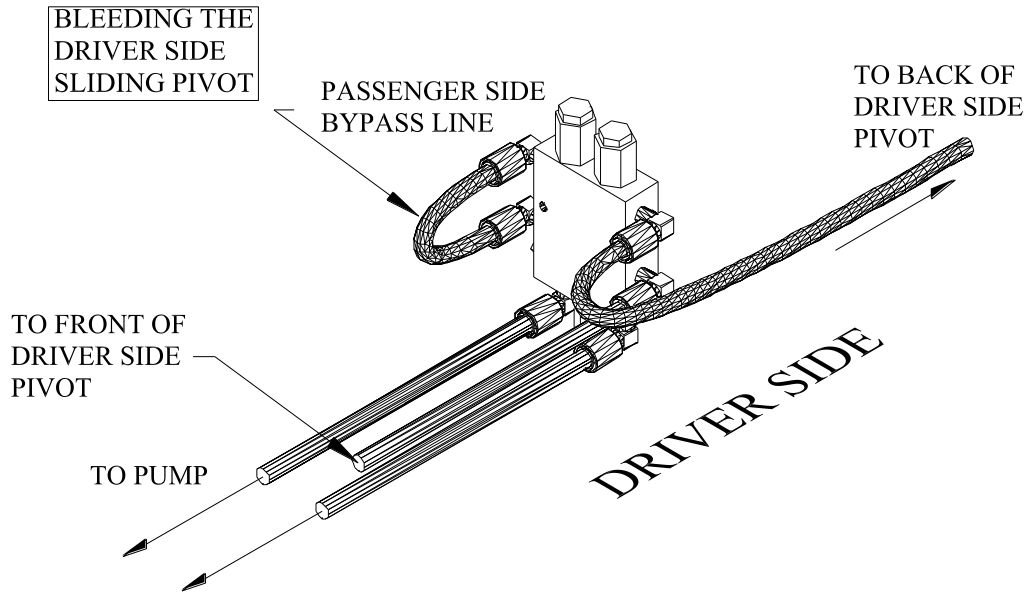

Figure 12

Bleeding the Sliding Pivots

*Note you will need to add additional fluid to complete this process. System comes from the factory with standard ATF – you must use a compatible fluid when bleeding system

- 1) Run the pivot back and forth at least 3 times.
- 2) Plumb the opposite side for bleeding. (Refer to Fig. 13)

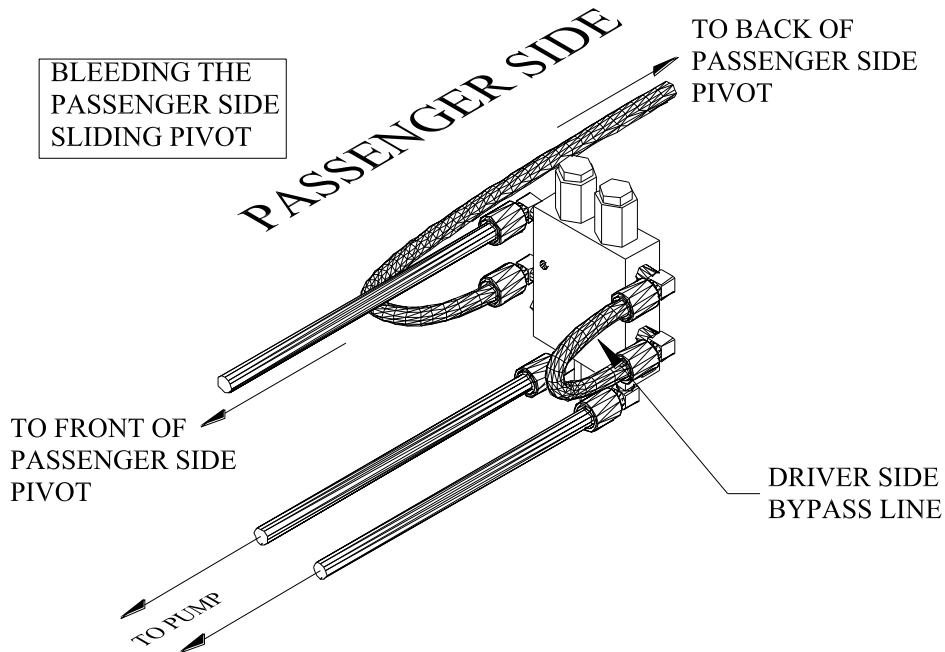

Figure 13

- 3) Run pivot back and forth at least 3 times.

Plumbing the System for Operation

Now that the cylinders are free of air, you will need to connect the cylinder hoses to the synchronizing valve as shown in Fig. 14

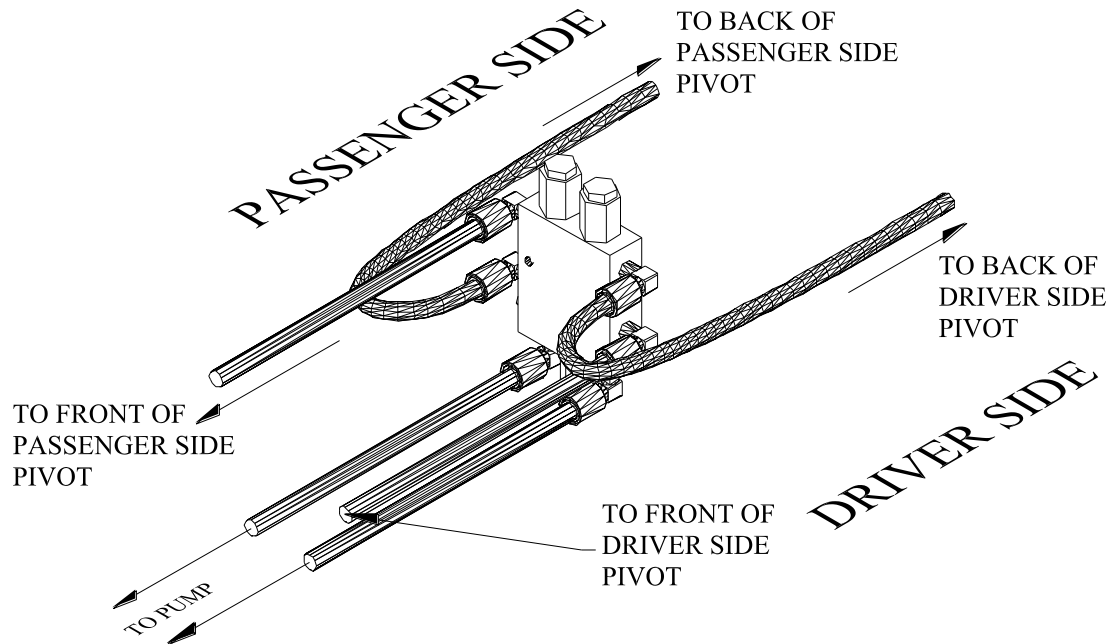

Figure 14

Run the pivots all the way to the rear. The pivots may not run in sync with one another right away. If this happens, the first pivot will hit and stop. The synchronizing valve will allow the other side to catch up. Leave the pivots to the rear.

*Questions? Contact Customer Service @ 800-297-9905
Or*

Parts Diagrams see "Parts and Diagrams" section on web at www.rollrite.com

Before Continuing:

Make sure that the Tower and Pivots have already been installed. If Pivot tubes are not attached to the pivot pins do so now.

Tarp Installation

- 1) Open the tarp and lay it out across the frame of the hoist with the pocket end to the rear of the truck and the finished side up.
- 2) Using the 5 - 5/16" x 5/8" button head bolts provided, bolt the tarp to the top of the tarp axle in one of the 5 pre-threaded grooves.

Arm Tie Down Installation

- 1) If your pivot set has 6 or more springs per side it came with a set of tie down brackets (see Fig. 1).

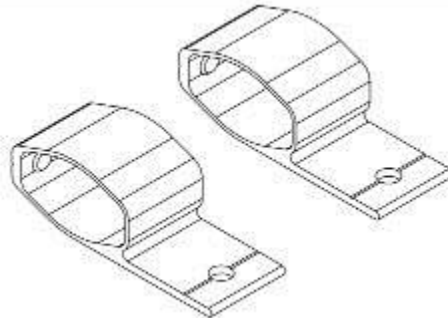

Fig. 1

- 2) With the pivot tube attached to the pivot spring pack slide the tie down over the pivot tube with the flange pointing down. Slide the tie down as far on as you can go and slightly snug one set screw (see Fig. 2).



Fig. 2

- 3) Repeat step 2 on opposite side
- 4) Complete Tarp Bow Installation below.
- 5) Wind the tarp so that the arms are in the position they will be at when the largest container is loaded.
- 6) Loosen the set screw and position the tie down as far up the arm as it can be while still allowing it to be reached from the ground and tighten both set screws (snug plus about 3/4 of a turn).
- 7) Repeat step 6 on opposite side

*Questions? Contact Customer Service @ 800-297-9905
Or*

Parts Diagrams see "Parts and Diagrams" section on web at www.rollrite.com

Tarp Bow Installation

*If installing 45° offsets do step 3 & 4 and then proceed to Offset Instructions

- 1) Bolt the supplied 90° corners in one end of each of the 98" bow arms.
- 2) Slide one of the bow tubes that have 90° corners bolted in the end all the way into the open end of the pivot arm. DO NOT TIGHTEN SET SCREWS AT THIS TIME.
- 3) Slide the rear bar into the pocket so that an equal amount extends out each side.
- 4) Install 1-2 tarp flanges on each side, depending on the amount of room available between the tarp and the pre-drilled 5/16" holes in the ends of the rear bar. Tighten set screws in each tarp flange.
- 5) Rotate the pivot arm and bow side arms up and insert the exposed end of the 90° into the ends of the rear bar that is in the pocket of the tarp and bolt in place.
- 6) With the tower in the lowest operational position and the pivots in the rear most position (if you have sliding pivots) power up the black control box and wind the tarp in, the tarp should roll over top of the tarp axle. This will rotate the arms forward. As the arms rotate forward they will slide out of the pivot tubes until they reach the tarp spool. Once the tarp is fully retracted and the arms are lying evenly against the tarp spool tighten the set screws (snug plus $\frac{3}{4}$ of a turn) in the pivot arms, to hold the bow arms in place.

Note: If it looks as if you are going to pull the bow arm completely out of the pivot tubes you should tie the pivot tubes forward before you completely wind the tarp. If the pivot point and pivot size are correct the arms will not come all the way out.

- 7) Go back to step 5 in the Arm Tie Down Installation section and position tie downs.

At this point the tarp system is fully installed. Test run all features of the tarping system.

- a. Deploy at least several feet of tarp.
- b. Raise and lower the tower.
- c. If equipped with sliding pivots - slide pivots fore and aft.

Questions? Contact Customer Service @ 800-297-9905

Or

Parts Diagrams see "Parts and Diagrams" section on web at www.rollrite.com

45° Pivot Tube Offset Installation:

**** When installing 45° Offset the main arm must not go below horizontal when the tarp is fully wound into the housing. ****

DC 400 & DC 300 Series Tarping Systems

- 1) Locate the driver side pivot box (see Fig. 1) and remove the springs.

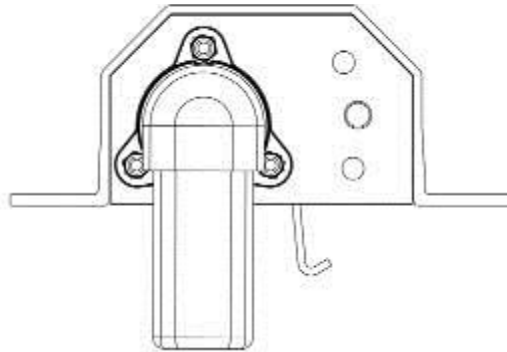

Fig. 1

- a. Remove the snap ring.
 - b. Pull pivot pin out of box.
 - c. While taking note of the springs orientation, so you can put them back in later, remove the springs from the pivot box.
 - d. Reinstall the pivot pin.
- 2) Assemble the upper arm sections (see Fig. 2)
 - a. Slide the 45° elbow into the drilled end of the pivot tube extension and bolt in place using the provided 3/8" x 5/8" button head bolts.
 - b. Slide the 90° elbow into one end of the bow tube and bolt in place using the provided Binding Post bolts.
 - c. Slide the open end of the bow tube all the way into the open end of the pivot tube extension and set screw in place with 1/2" x 3/8" set screw.

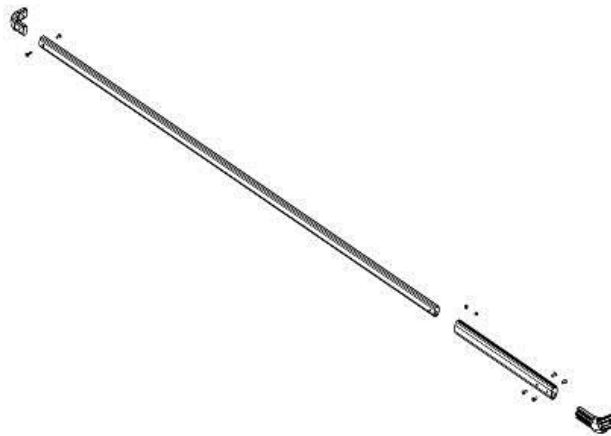

Fig. 2 (Upper Arm Assembly)

Questions? Contact Customer Service @ 800-297-9905
Or

Parts Diagrams see "Parts and Diagrams" section on web at www.rollrite.com

Steps 3 – 9 refer to Fig. 3

- 3) Loosely bolt the pivot box onto the truck where it will be mounted.
- 4) Slide pivot tube onto the pivot pin and set screw in place.
- 5) Rotate the arm forward until it is in the desired location or angle from the frame rail and prop in this position (see "Z°" in Fig. 3).
- 6) With the Tower in the lowered or park position, hold the upper arm assembly up so the 45° corner is in front of & parallel with the pivot tube, which was positioned in step 4.
- 7) Slide the upper arm assembly (created in step 2/ Fig. 2) back and forth along the pivot tube until the bow tube lines up centered on the rubber pad on top of the tarp spool.

Note: Make sure the arm will not hit the gear motor

- 8) With the upper arm assembly held in position mark the Pivot tube at the flare of the 45° elbow, illustrated by dimension "X" in Fig. 3.
- 9) Still with the upper arm assembly held in place measure from the center of the rubber pad on the tarp spool housing to the end of the bow tube, below the 90° corner. This is dimension "Y" in Fig. 3. Record this measurement.

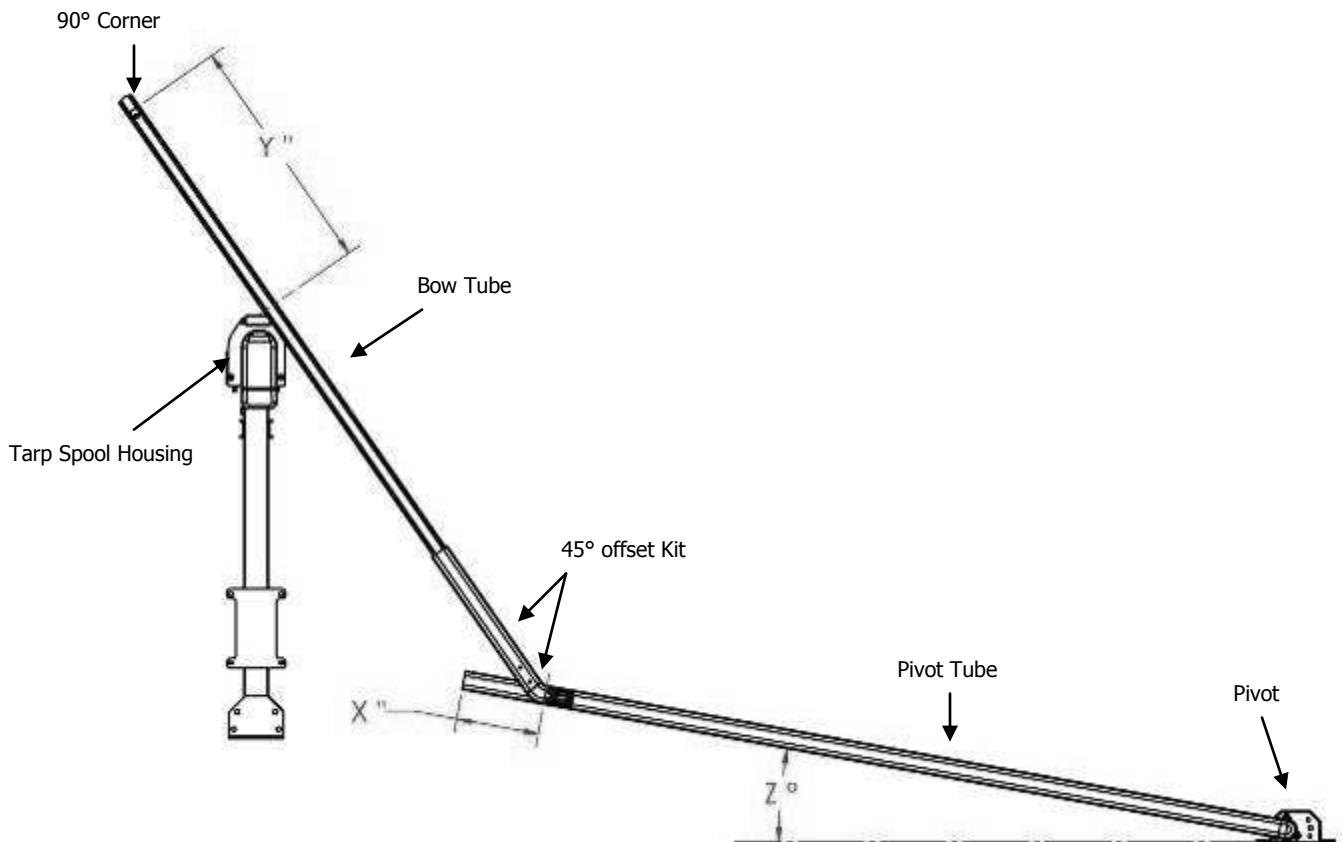

Fig. 3

- 10) Remove arms from truck.
- 11) Cut an amount equal to dimension "X" from Fig. 3 off both the driver and the passenger side pivot tubes.

Questions? Contact Customer Service @ 800-297-9905
Or

Parts Diagrams see "Parts and Diagrams" section on web at www.rollrite.com

- 12) Mark and drill the cut ends of the pivot tubes to accept the 45° elbows (see Fig. 4).

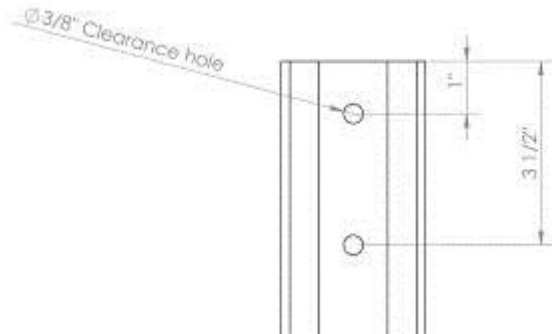

Fig. 4

- 13) Using the "Y" measurement obtained in step 9, measure from the open/bottom end of the driver and passenger side bow tubes and cut them off if needed.
- 14) Re-Assemble arm on pivot box and swing arm back to the front to make sure everything fits as needed. If so remove from truck.
- 15) Reassemble the driver side pivot box while making sure to reinstall the springs in the same position as they came out.
- 16) Move the clevis pin in both the driver and passenger side pivot boxes to the top hole (see Fig. 5).

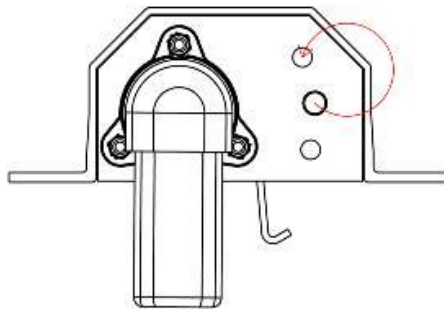

Fig. 5

- 17) Re-install the pivot box and arms on truck and connect to tarp bar and tarp.

DC 350 Series Tarping Systems

- 1) Drill one end of both of the 96" long pivot tubes per Fig. 4.
- 2) Slide the pivot tubes in the socket tubes on the spring packs until they are flush with the lower end of the sockets (indicated by arrow in Fig. 6) leaving the end drilled in step one out.

*Questions? Contact Customer Service @ 800-297-9905
Or*

Parts Diagrams see "Parts and Diagrams" section on web at www.rollrite.com

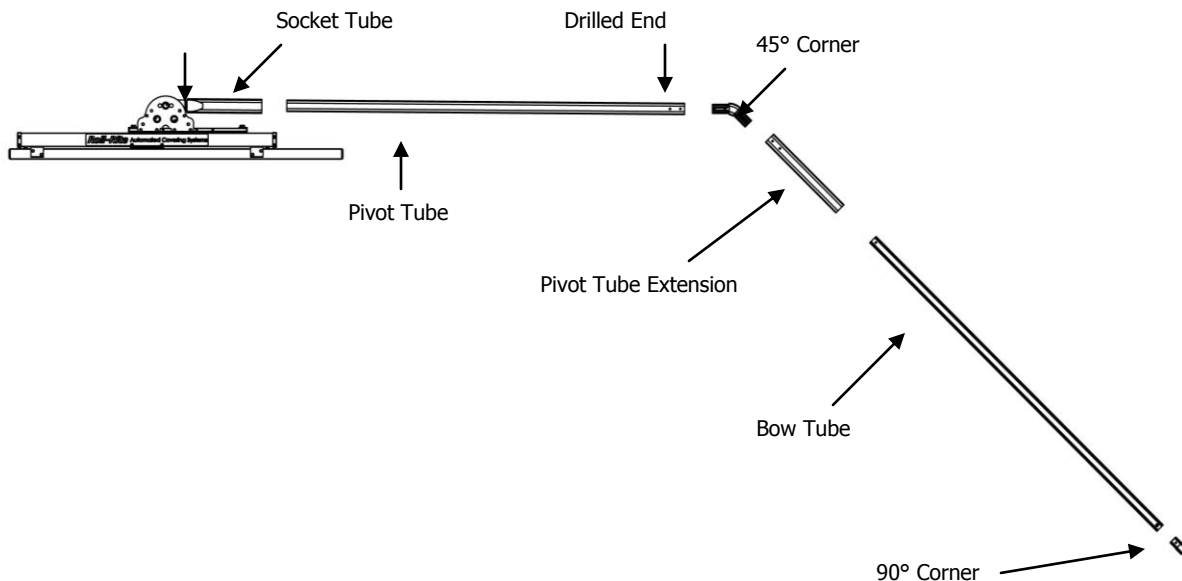

Fig. 6

- 3) Slide 45° elbows into open ends of pivot tube and bolt in place using the provided 3/8" x 5/8" button head bolts.
- 4) Slide the 24" pivot tube extensions on the open ends of the 45° elbows and bolt in place.
- 5) Bolt the 90° corners in one end of 2 of the bow tubes using the provided Binding Post bolts.
- 6) Slide the open end of the bow tubes into the 24" pivot tube extensions until they come up against the 45° elbow. Do not tighten set screws yet.
- 7) With the rear bar installed in the tarp connect the 90° corners to the rear bar.
- 8) With the pivots slid all of the way back and the tower in the park (typically all the way down) position – wind the tarp in until the lower pivot tube is horizontal (**Important – Do Not Go Past Horizontal.**) The rear bar should land centered on top of the tarp spool housing roughly when the lower tube is horizontal. If so tighten the set screws to hold the bow arms in place (snug plus 3/4 of a turn).
- 9) If the rear bar is not all the way down to the tarp spool housing or is sticking forward of the tarp spool housing when the lower pivot tube is horizontal, some additional modifications will be required.
 - a. Measure how far beyond or above the bar is landing at the top center of the tarp spool housing & record this distance.
 - b. Unwind the tarp and remove the bow tubes from the pivot extensions.
 - c. Cut the amount recorded in step "a" off both of the bow tubes.
 - d. Reinstall the bow tubes and wind the tarp back into the tarp spool housing.
 - e. Double check that the pivot tubes are not rotated beyond horizontal. If so you will need to reset to horizontal and adjust starting at step "a."

Questions? Contact Customer Service @ 800-297-9905

Or

Parts Diagrams see "Parts and Diagrams" section on web at www.rollrite.com